



16 tm

ORMIG S.p.A.

TEL. (+39) 0143 80051 r.a.
TELEFAX (+39) 0143 86568
E-mail: mktg@ormigspa.com
E-mail: sales@ormigspa.com
www.ormig.com - www.pickandcarry.com

ORMIG S.p.A.
PIAZZALE ORMIG
P.O. BOX 63
15076 OVADA (AL)
ITALY

CARATTERISTICHE TECNICHE



Carro:	4x2x2
Telaio:	Struttura in acciaio ad alta qualità, composta da longheroni in tubolare a sezione rettangolare, collegati nella parte inferiore e posteriore in corrispondenza dell'assale anteriore e delle spalle.
Motore:	Diesel PERKINS 1104C-44T, 4 cilindri, 4400 c.c., 74,5kW a 2300 giri/min. Capacità serbatoio combustibile 200 litri.
Cambio:	Trasmissione con convertitore di coppia DANA 4 marce avanti + 3 retromarce.
Assali:	Anteriore motore, rigido. Posteriore sterzante, oscillante al centro.
Pneumatici:	10.00 R20, gemellati su asse anteriore e singoli su quello posteriore.
Sterzo:	Idrosterzo con idroguida DANFOSS.
Freni:	Conformi alla normativa CEE. Freno di servizio e di emergenza con azionamento idraulico agente sulle ruote anteriori e posteriori. Freno di stazionamento meccanico a molla agente sulle ruote anteriori, sbloccabile idraulicamente.
Posto di guida:	Cruscotto completo di strumentazione, comandi, sedile ergonomico e protezioni conducente.
Impianto elettrico:	Tensione di esercizio 24 V. Alternatore da 75 A. N° 2 batterie da 100 Ah.
Braccio:	Realizzato in lamiera ad alta resistenza. Il braccio è composto da un elemento di base fisso e da due prolunghe sfilabili oleodinamicamente mediante cilindri a doppio effetto. Gancio fisso in testa al braccio.
Impianto idraulico:	N°1 pompa assiale a pistoni a cilindrata variabile; distributore idraulico proporzionale compensato con valvole di taratura; manipolatori idraulici. Capacità serbatoio olio 165.
Dispositivo di controllo del carico:	Elettronico di tipo attivo con blocco delle funzioni che incrementano le situazioni di pericolo e conforme alle norme vigenti.
Omologazione stradale:	La gru è omologata come Macchina Operatrice a libera circolazione nel rispetto del Codice della Strada e del D.M. del 14/06/85.
Pesi:	Peso Totale 14100 kg - Asse anteriore 4900 kg - Asse posteriore 9200 kg.
Applicazioni a richiesta:	<ul style="list-style-type: none">• Cabina di guida completa di riscaldamento• Argano con fune, bozzetto e fine corsa• Braccetti speciali idraulici e meccanici• Forche• Contrappeso extra

TECHNICAL FEATURES

Carrier:	4x2x2
Frame:	Structure from high quality steel, with pipes at rectangular section, connected in the front and rear part to the front axle and to the upper structure.
Engine:	Diesel Perkins 1104C-44T, 4 cylinders, 4400 c.c., 74,5 kW at 2300 rpm Fuel tank 200 litres.
Speed gearbox:	DANA transmission with torque converter, 4 forward and 3 reverse speeds.
Axles:	Front rigid driving axle. Rear steering axle with central oscillation.
Tyres:	10.00 R20, double tyres at front axle and single tyre at rear axle.
Steering:	Hydraulic steering with hydraulic drive DANFOSS.
Brakes:	In compliance with EEC regulations. Hydraulic service and emergency brake at front and rear wheels. Mechanic parking brake, spring type, at front wheels, with hydraulic unlock control.
Driving place:	Dashboard complete with all controls and indicators, ergonomic seat and protections for the driver.
Electric system:	24V, alternator 75A - 2 batteries of 100 Ah
Boom:	Fabricated from plate at high strength. It is formed by a fix base and two extensions at oleodynamic extraction by means of double acting cylinders. Fix hook at boom head.
Hydraulic system:	One axial pistons pump at variable delivery; compensated hydraulic proportional distributor with calibration valves; hydraulic keysenders.
Safe load device:	Electronic, active type, providing cut out of the controls which can cause dangerous conditions and in compliance with regulations in force.
Road certification:	The crane can be certified for travelling on road.
Weight:	Total weight 14100 Kg Front axle 4900 Kg Rear axle 9200 Kg
Equipment on request:	<ul style="list-style-type: none">• Closed cab with heater• Winch with rope, hookblock and end of stroke• Hydraulic and mechanic special flyjibs• Forks• Additional counterweight

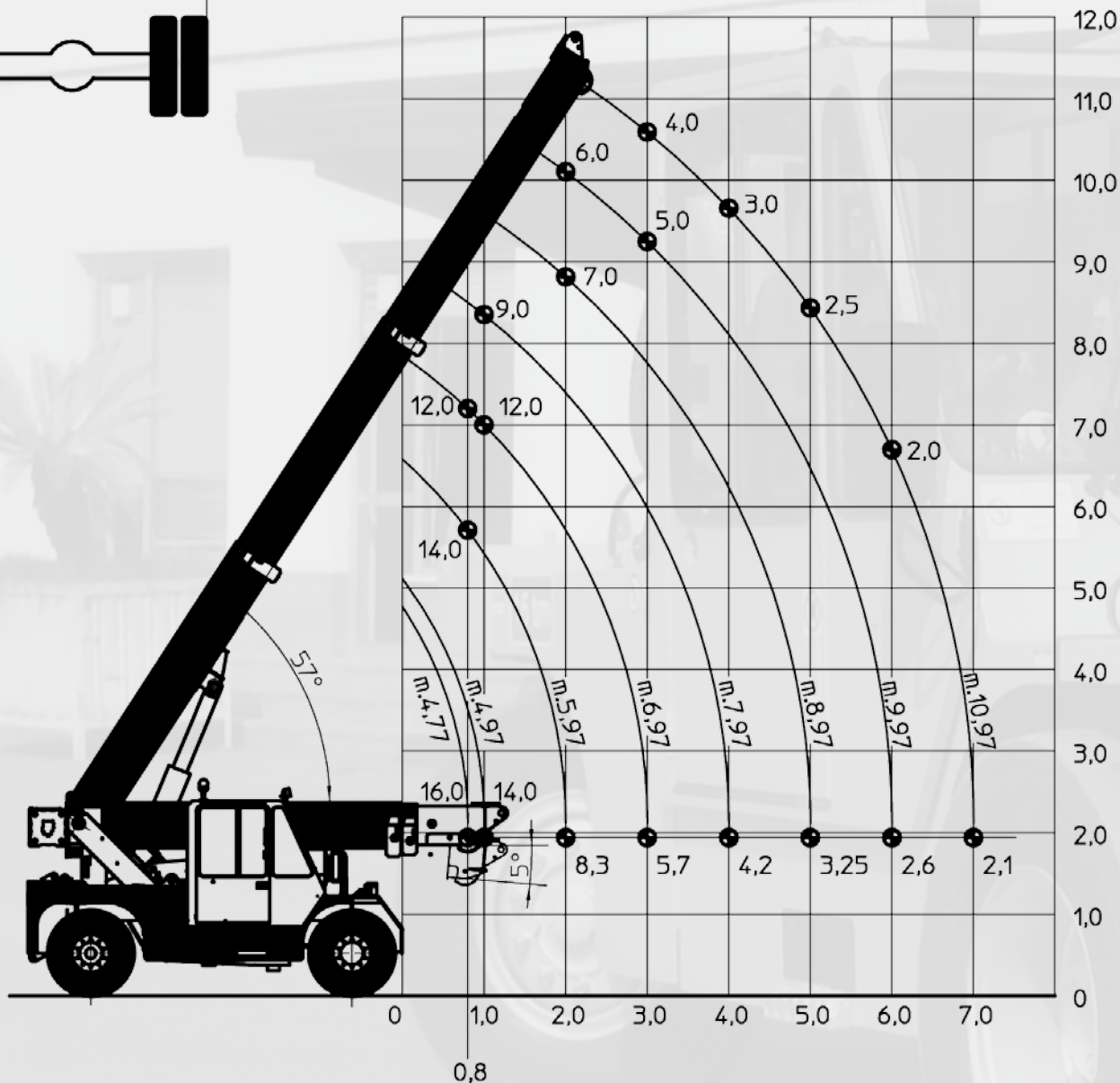
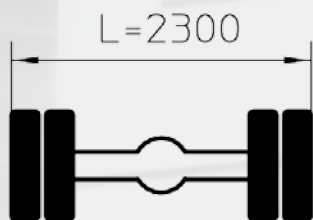

- * Portate determinate da fattori diversi dal ribaltamento
- * Capacities determined by factors other than tipping load

Lifting capacity chart (tonnes)

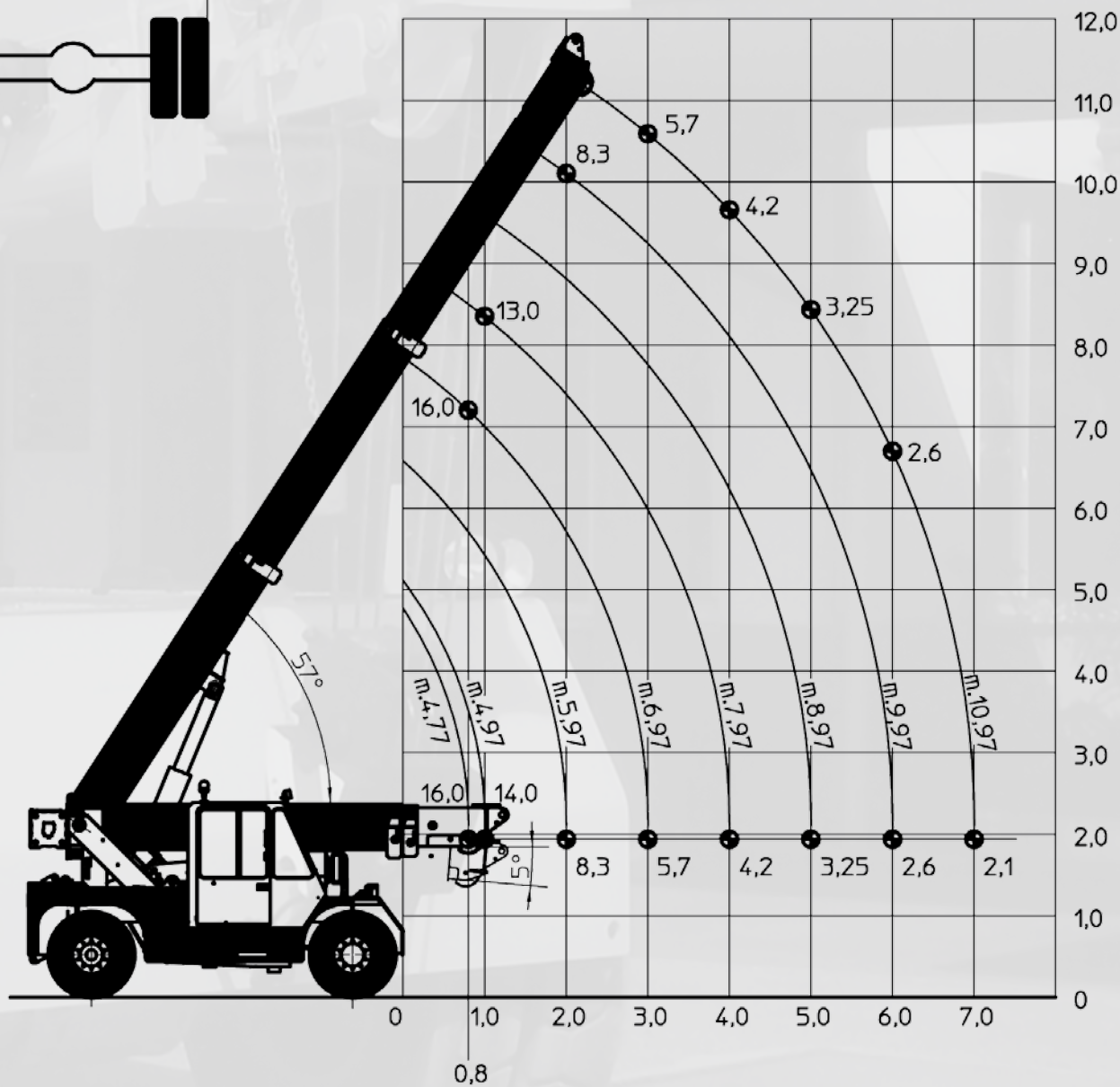

- * Portate determinate da fattori diversi dal ribaltamento
- * Capacities determined by factors other than tipping load

Lifting capacity chart with forks (tonnes)

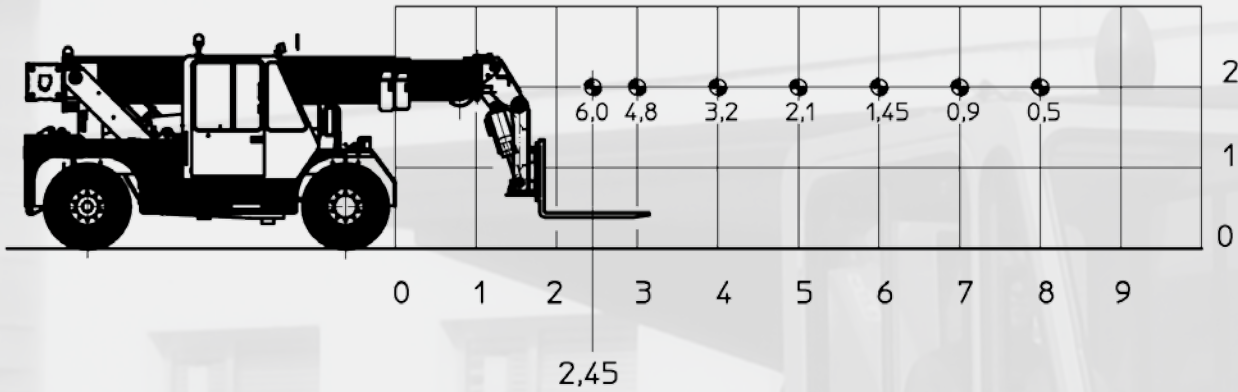
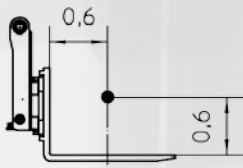

Lifting capacity Chart with fly - jibs (tonnes)

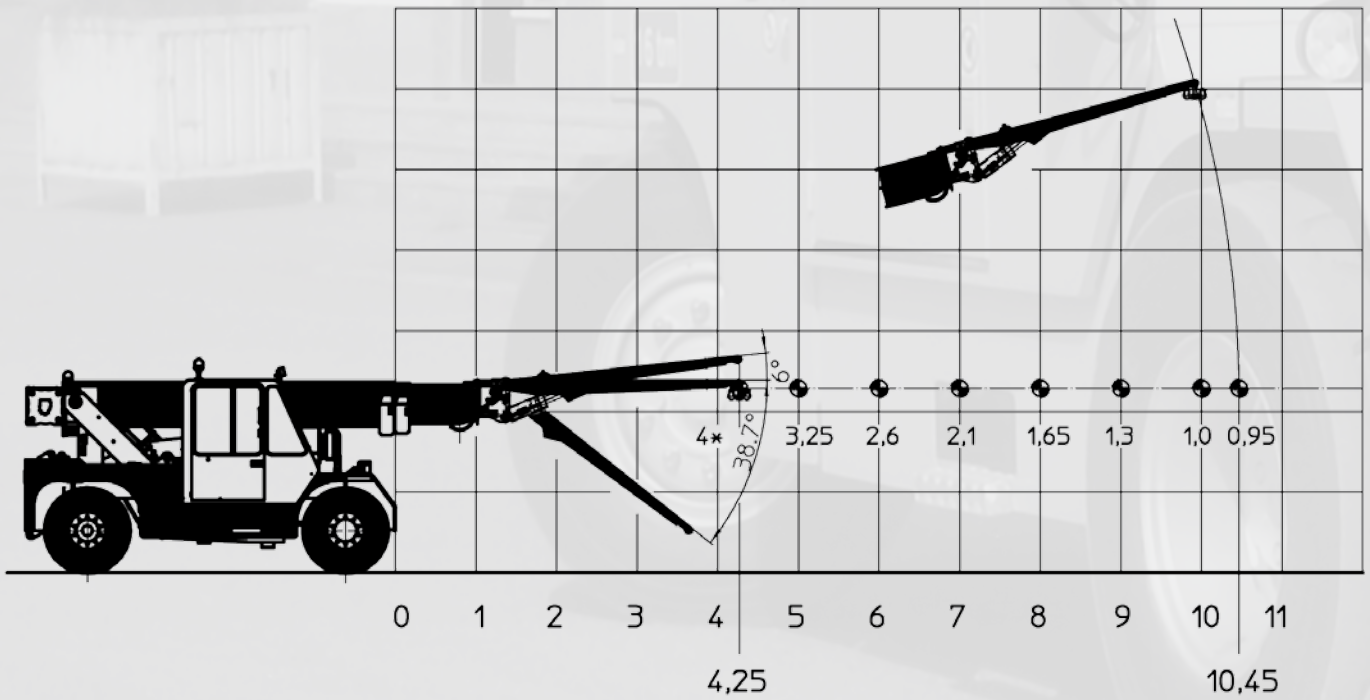

- * Portate determinate da fattori diversi dal ribaltamento
- * Capacities determined by factors other than tipping load

Dimensioni Generali

General Dimensions

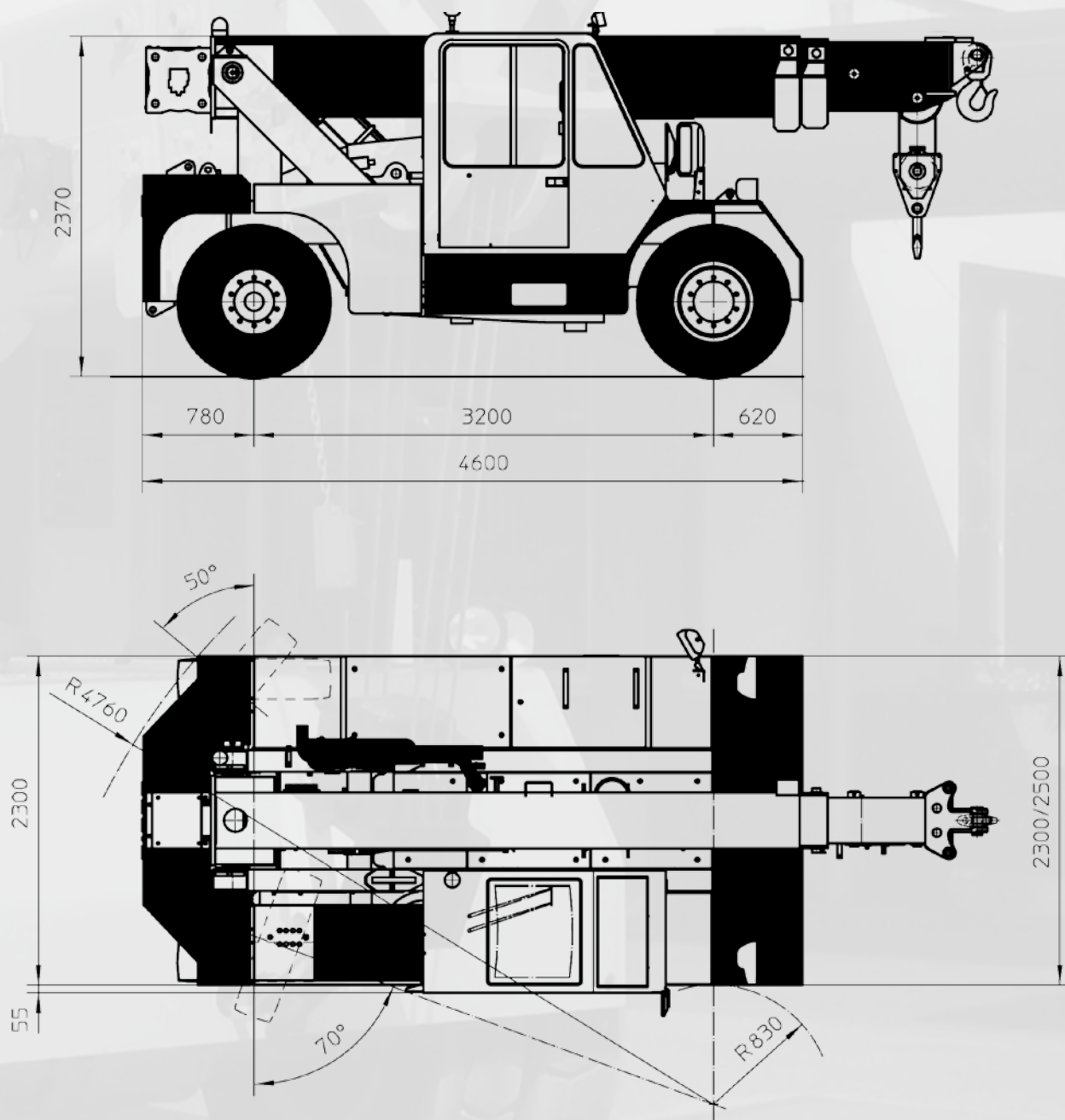



TEL. (+39) 0143 80051 r.a.
TELEFAX (+39) 0143 86568
E-mail: mktg@ormigspa.com
E-mail: sales@ormigspa.com
www.ormig.com - www.pickandcarry.com

ORMIG S.p.A.
PIAZZALE ORMIG
P.O. BOX 63
15076 OVADA (AL)
ITALY